

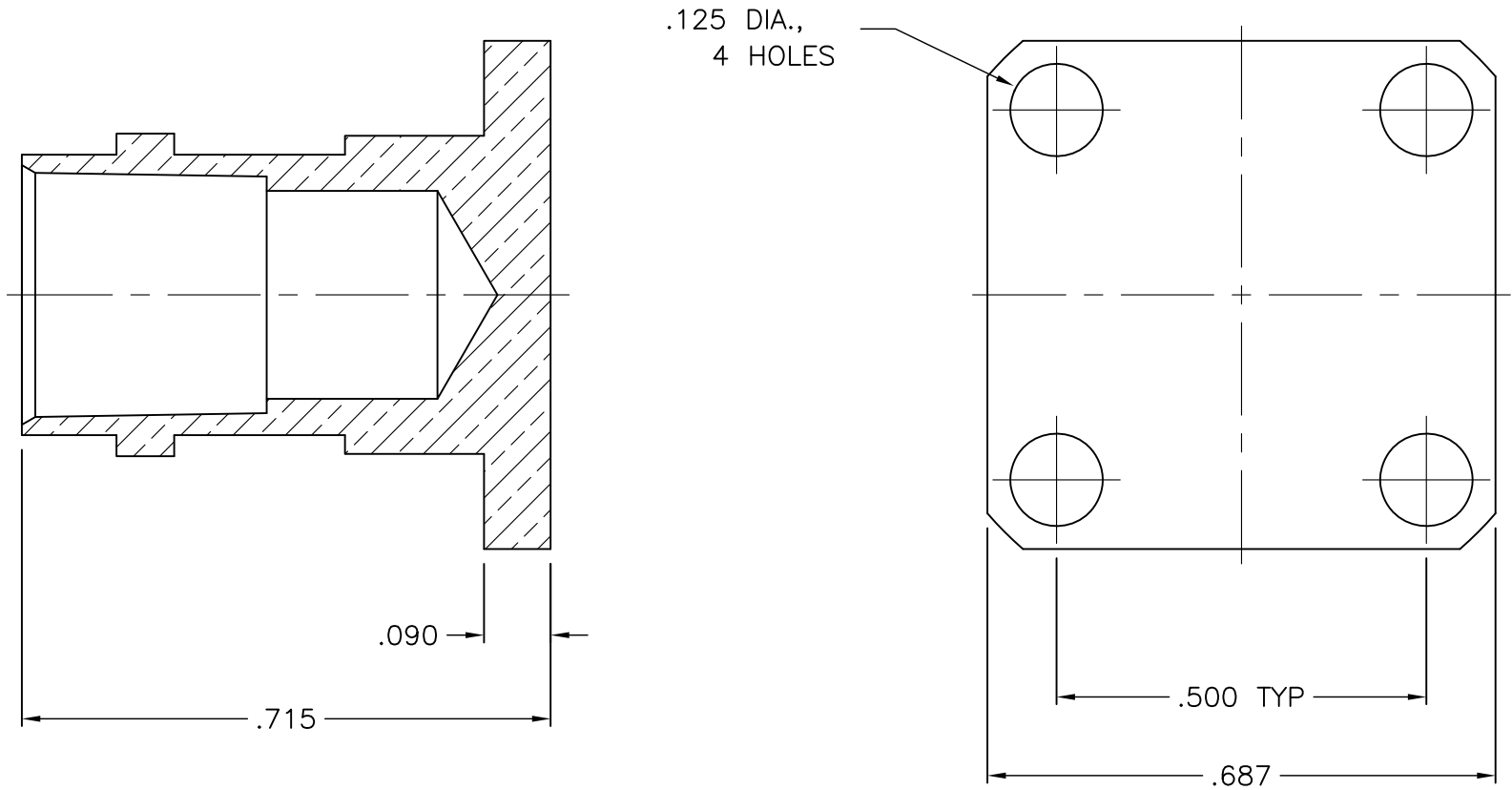

1063-000-N090



NOTES:

- 1. MATERIAL: BODY - BRASS PER ASTM B16
- 2. FINISHES: BODY - NICKEL PLATE PER QQ-N-290

UNLESS OTHERWISE SPECIFIED: TOLERANCES: 3 PLACES = ±.005, 2 PLACES = ±.02, ANGLES = ±1/2°, SURFACE FINISH = 63	-	OUTLINE	8/4/11
	ALT.	REVISIONS	DATE

DELTA ELECTRONICS MFG. CORP. Beverly, MA 01915				
TITLE: "BNC" JACK DUMMY RECEPTACLE				
Drawn by MR 8/4/11	Scale 4/1	Ckd. by BJM	Engr Appd MR	FILE NAME: 1063000N090-000T
CODE IDENT.-00795			1063-000-N090	

THESE DRAWINGS AND SPECIFICATIONS ARE THE PROPERTY OF DELTA ELECTRONICS MFG CORP. AND SHALL NOT BE REPRODUCED, OR COPIED OR USED AS THE BASIS FOR THE MANUFACTURE OR SALE OF APPARATUS OR DEVICES WITHOUT THEIR EXPRESS WRITTEN CONSENT.