

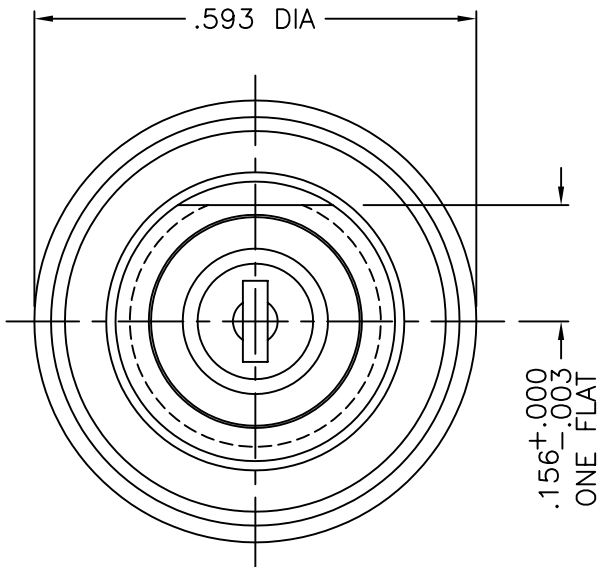

1047-000-A63F

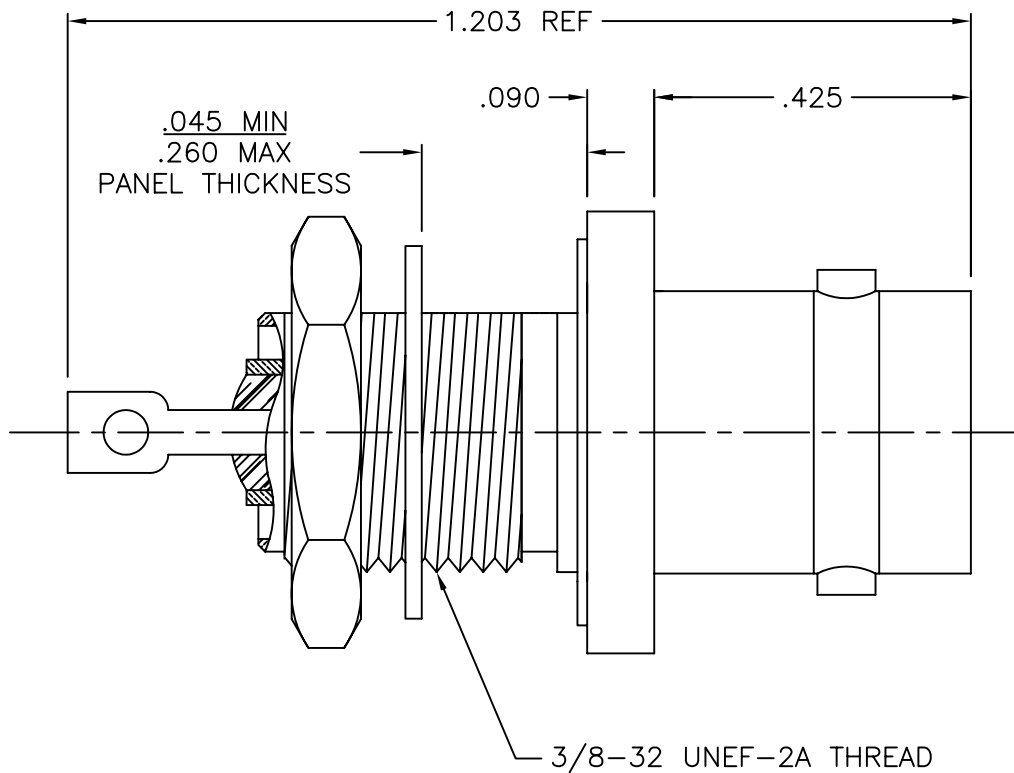

VIEW SHOWN WITH HEX. NUT
& LOCKWASHER REMOVED



NOTES:

- ASSEMBLED CONNECTOR INTERFACE IS DESIGNED IN ACCORDANCE WITH MIL-STD-348.
- MATERIAL: BODY & HEX NUT- BRASS PER ASTM B16
 LOCKWASHER - SPRING STEEL
 CONTACT - BERYLLIUM COPPER PER ASTM B196.
 BUSHING - BRASS PER ASTM B16.
 GASKET - SILICONE RUBBER PER ZZ-R-765
 INSULATOR - TEFLON PER ASTM D1710
- FINISHES: CONTACT - GOLD PLATE PER MIL-G-45204
 ALL OTHER METAL PARTS - SILVER PLATE PER QQ-S-365

UNLESS OTHERWISE SPECIFIED: TOLERANCES: 3 PLACES = ±.005, 2 PLACES = ±.02, ANGLES = ±1/2°, SURFACE FINISH = 63

-	OUTLINE	4/10/07
ALT.	REVISIONS	DATE

M39012/24-0002

DELTA ELECTRONICS MFG. CORP. Beverly, MA 01915					
TITLE: 'BNC' STRAIGHT BULKHEAD JACK RECEPTACLE-REAR MOUNT, HERMETIC SEALED					
Drawn by DG	Scale 4/1	Ckd. by MR	Engr Appd MR	FILE NAME: 1047000A63F-000T	
4/10/07					

THESE DRAWINGS AND SPECIFICATIONS ARE THE PROPERTY OF DELTA ELECTRONICS MFG CORP. AND SHALL NOT BE REPRODUCED, OR COPIED OR USED AS THE BASIS FOR THE MANUFACTURE OR SALE OF APPARATUS OR DEVICES WITHOUT THEIR EXPRESS WRITTEN CONSENT.

CODE IDENT.-00795 1047-000-A63F