

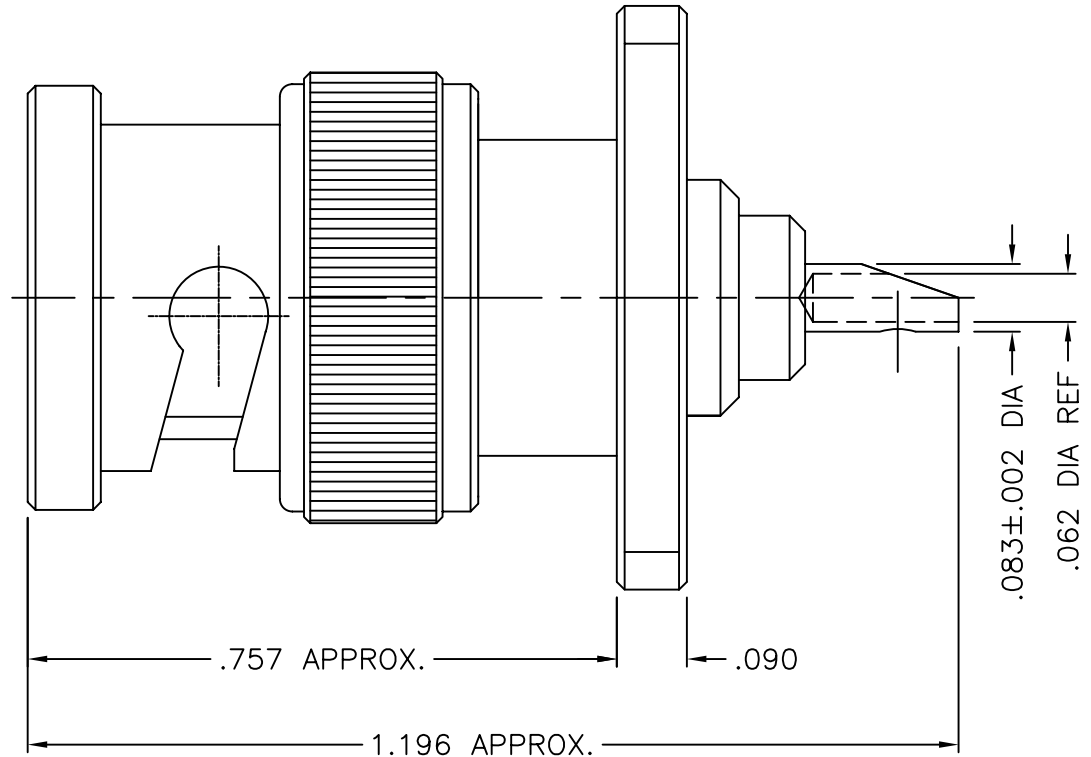

1023-000-N180-2

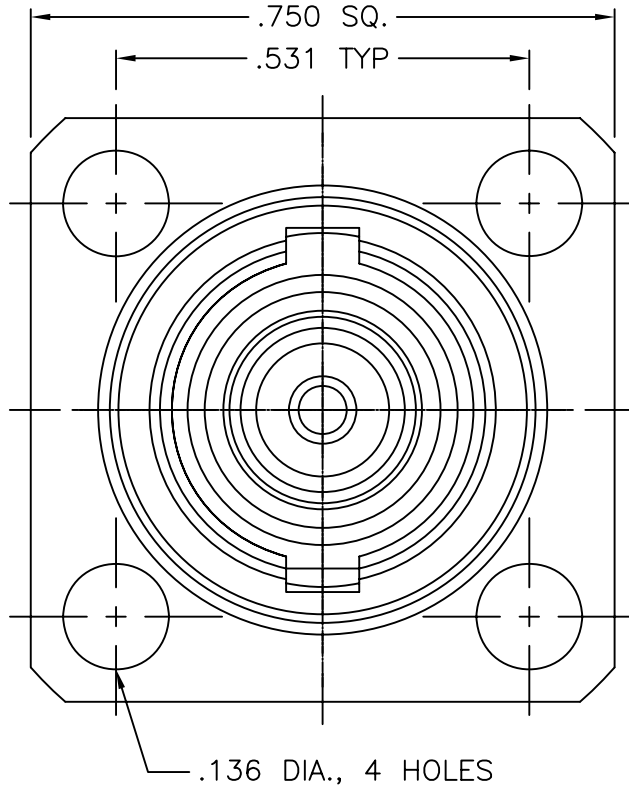

NOTES:

1. ASSEMBLED CONNECTOR INTERFACE IS DESIGNED IN ACCORDANCE WITH MIL-STD-348.
2. MATERIAL: BODY, BAYONET SLEEVE, HALF WASHERS - BRASS PER ASTM B16
 CONTACT & FINGERS - BRASS PER ASTM B16.
 SPRING WASHER - BERYLLIUM COPPER PER ASTM B196.
 GASKET - SILICONE RUBBER PER ZZ-R-765
 INSULATORS - TEFLON PER ASTM D1710
3. FINISHES: CONTACT - SILVER PLATE PER QQ-S-365
 ALL OTHER METAL PARTS - NICKEL PLATE PER QQ-N-290

UG-1104 A/U

DELTA ELECTRONICS MFG. CORP. Beverly, MA 01915

TITLE: 'BNC' PANEL PLUG RECEPTACLE
 WITH CAPTIVE SOLDER POT CONTACT

UNLESS OTHERWISE SPECIFIED: TOLERANCES: 3 PLACES = ±.005, 2 PLACES = ±.02, ANGLES = ±1/2°, SURFACE FINISH = 63	-	OUTLINE	6/26/06
	ALT.	REVISIONS	DATE

Drawn by DG 6/26/06	Scale 4/1	Ckd. by MR	Engr Appd MR	FILE NAME: 1023000N180-002T
---------------------------	--------------	---------------	-----------------	--------------------------------

THESE DRAWINGS AND SPECIFICATIONS ARE THE PROPERTY OF DELTA ELECTRONICS MFG CORP. AND SHALL NOT BE REPRODUCED, OR COPIED OR USED AS THE BASIS FOR THE MANUFACTURE OR SALE OF APPARATUS OR DEVICES WITHOUT THEIR EXPRESS WRITTEN CONSENT.

CODE IDENT.-00795

1023-000-N180-2