

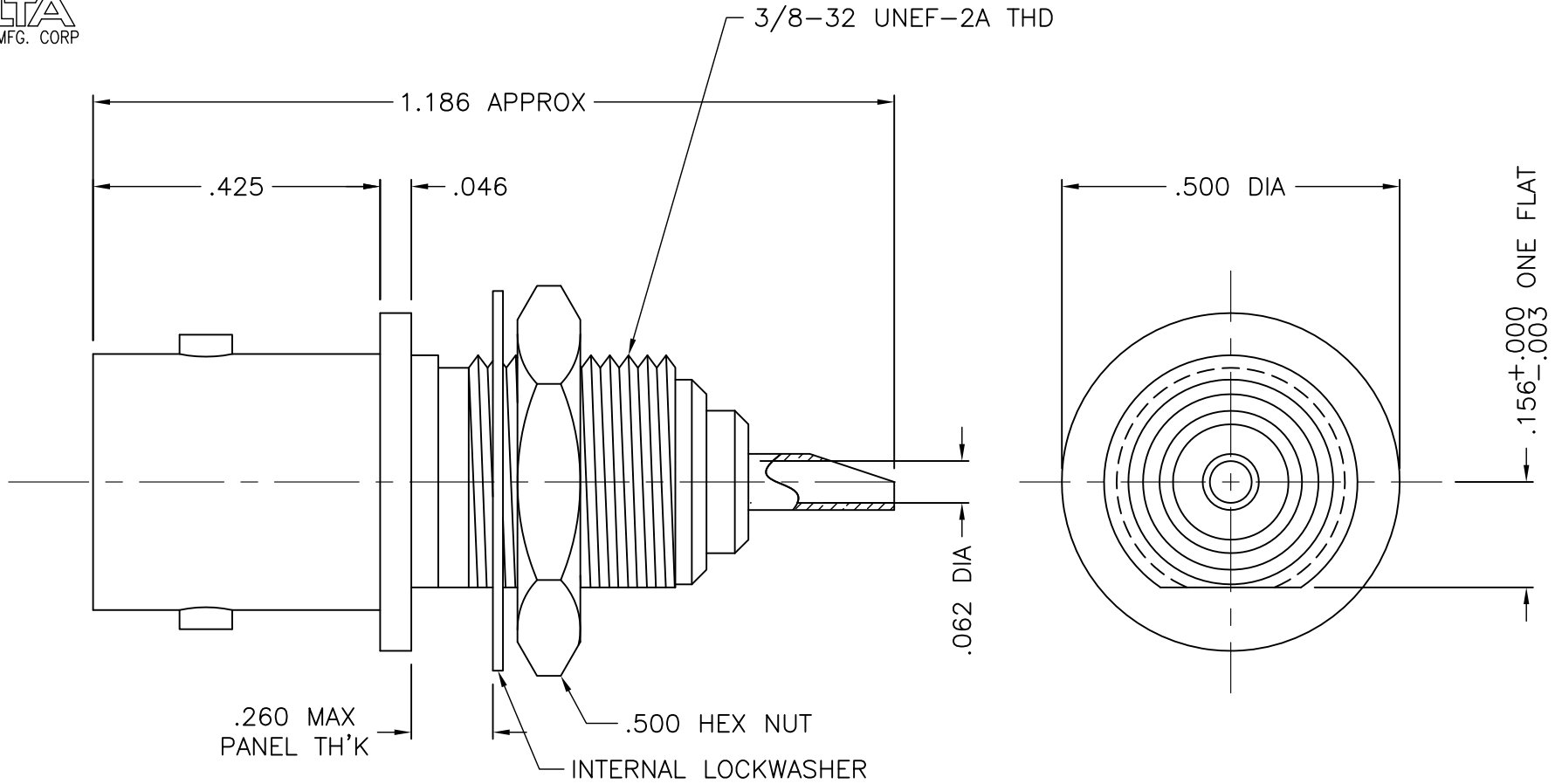

1020-000-N65G



NOTES:

1. ASSEMBLED CONNECTOR INTERFACE IS DESIGNED IN ACCORDANCE WITH MIL-STD-348.
2. MATERIAL: CONTACT - BERYLLIUM COPPER PER ASTM B196.
INSULATOR - TEFLON PER ASTM D1710
ALL OTHER METAL PARTS - BRASS PER ASTM B16
3. FINISHES: CONTACT - SILVER PLATE PER QQ-S-365
BODY, LOCKWASHER, & HEX NUT - NICKEL PLATE PER QQ-N-290
4. ELECTRICAL:
 - A. NOMINAL IMPEDANCE: 50 OHMS.
 - B. VOLTAGE RATING: 500 VOLTS RMS MAX.
 - C. FREQUENCY RANGE 0 TO 4 GHz.
 - D. DIELECTRIC WITHSTANDING VOLTAGE: 1500 VOLTS RMS.

UG-1094A/U

UNLESS OTHERWISE SPECIFIED: TOLERANCES: 3 PLACES = ±.005, 2 PLACES = ±.02, ANGLES = ±1/2'

-	OUTLINE	12/15/08
ALT.	REVISIONS	DATE

DELTA ELECTRONICS MFG. CORP. Beverly, MA 01915				
TITLE: 'BNC' BULKHEAD (FRONT) MOUNTED JACK RECEPTACLE SOLDER POT CONTACT				
Drawn by BJM 12/15/08	Scale 4/1	Ckd. by MR	Engr Appd MR	FILE NAME: 1020000N65G-000T

THESE DRAWINGS AND SPECIFICATIONS ARE THE PROPERTY OF DELTA ELECTRONICS MFG CORP. AND SHALL NOT BE REPRODUCED, OR COPIED OR USED AS THE BASIS FOR THE MANUFACTURE OR SALE OF APPARATUS OR DEVICES WITHOUT THEIR EXPRESS WRITTEN CONSENT.

CODE IDENT.-00795

1020-000-N65G