

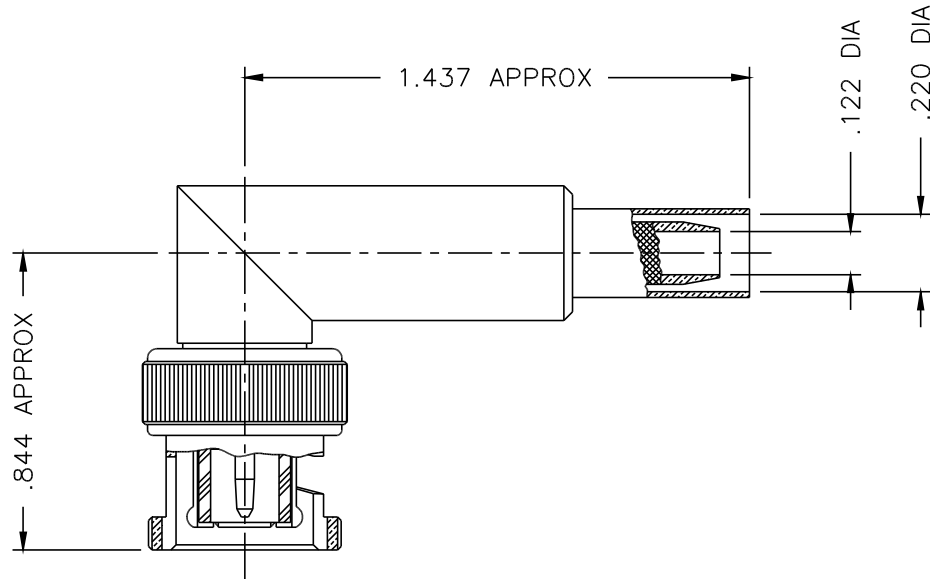

1007-015-N000



NOTES:

1. ASSEMBLED CONNECTOR INTERFACE IS DESIGNED IN ACCORDANCE WITH MIL-STD-348.
2. MATERIAL: CABLE CONTACT - BRASS PER ASTM B16
 90° CONTACT - BERYLLIUM COPPER PER ASTM B196
 INSULATOR - TEFLON PER ASTM D1710
 GASKET - SILICONE RUBBER PER ZZ-R-765
 ALL OTHER METAL PARTS - BRASS PER ASTM B16
3. FINISHES: CONTACT - SILVER PLATE PER QQ-S-365
 ALL OTHER METAL PARTS - NICKEL PLATE PER QQ-N-290
4. USE CRIMP TOOL M22520/5-19 CLOSURE B (.213 HEX DIE)

DELTA ELECTRONICS MFG. CORP. Beverly, MA 01915					
TITLE: 'BNC' (M) RT ANGLE CRIMP PLUG FOR RG-55, 142/U CABLE - NON-CAPTIVE CONTACT					
Drawn by MR	Scale 2/1	Ckd. by	Engr Appd	FILE NAME: 1007015N000-000T	
7/21/99					
CODE IDENT.-00795		1007-015-N000			

UNLESS OTHERWISE SPECIFIED: TOLERANCES: 3 PLACES = ±.005, 2 PLACES = ±.02, ANGLES = ±1/2°

-	OUTLINE	7/21/99
ALT.	REVISIONS	DATE

THESE DRAWINGS AND SPECIFICATIONS ARE THE PROPERTY OF DELTA ELECTRONICS MFG CORP. AND SHALL NOT BE REPRODUCED, OR COPIED OR USED AS THE BASIS FOR THE MANUFACTURE OR SALE OF APPARATUS OR DEVICES WITHOUT THEIR EXPRESS WRITTEN CONSENT.