

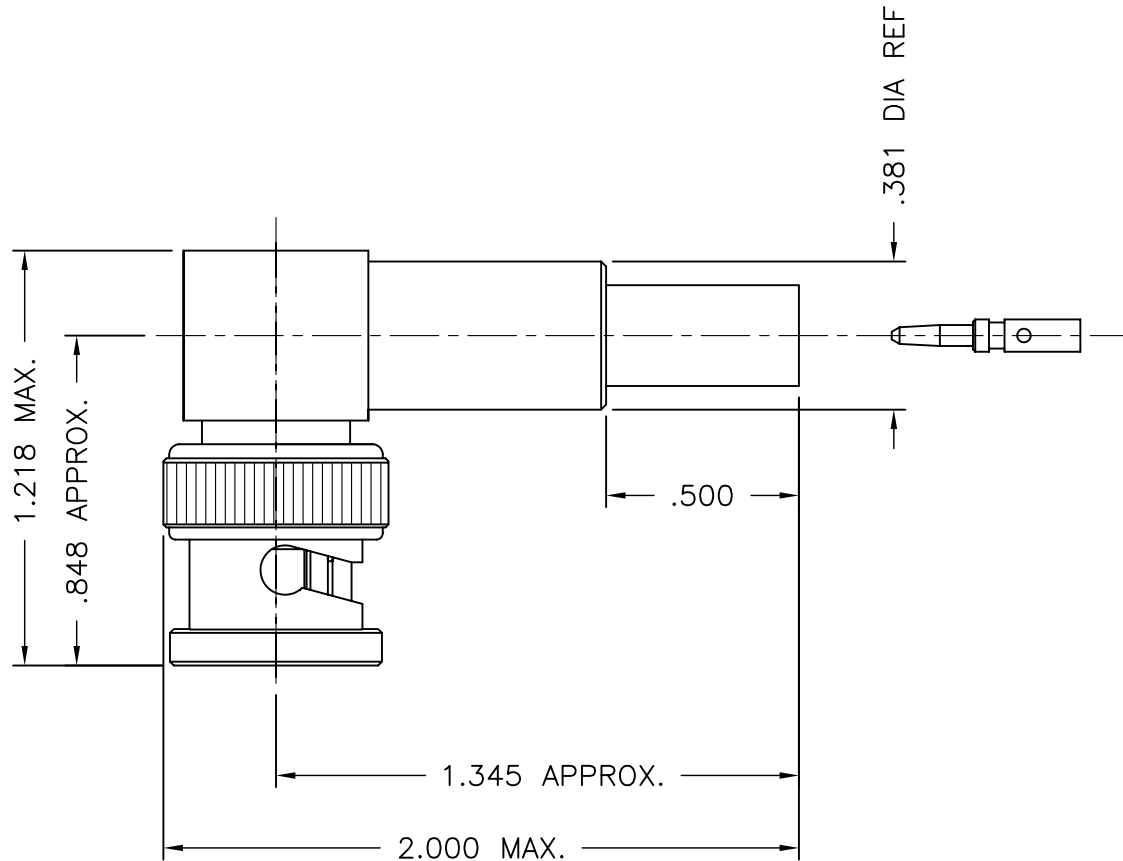

1007-013-A00E-3



**NOTES**

1. ASSEMBLED CONNECTOR INTERFACE IS DESIGNED IN ACCORDANCE WITH MIL-STD-348.
2. MATERIAL: CONTACT (F) - BERYLLIUM COPPER PER ASTM B196  
 INSULATORS - TEFLON PER ASTM D4894  
 GASKET - SILICONE RUBBER PER A-A-59588  
 CRIMP SLEEVE - D.H.P. COPPER CDA ALLOY 122  
 SPRING WASHERS - BERYLLIUM COPPER PER ASTM B196  
 ALL OTHER PARTS - BRASS PER ASTM B16
3. FINISHES: CONTACTS - GOLD PLATE PER ASTM B488  
 SPRING WASHERS - NICKEL PLATE PER AMS-QQ-N-290  
 ALL OTHER PLATED PARTS - SILVER PLATE PER ASTM-B700

M39012/20-0007

DELTA ELECTRONICS MFG. CORP. Beverly, MA 01915

TITLE: "BNC" RIGHT ANGLE CRIMP PLUG FOR  
 RG-142, 223, & 400/U CABLES

UNLESS OTHERWISE SPECIFIED: TOLERANCES: 3 PLACES = ±.005, 2 PLACES = ±.02, ANGLES = ±1/2', SURFACE FINISH = 63	-	OUTLINE	10/6/04	Drawn by BJM 10/6/04	Scale 2/1	Ckd. by MR	Engr Appd MR	FILE NAME: 1007013A00E-003T
	ALT.	REVISIONS	DATE					

THESE DRAWINGS AND SPECIFICATIONS ARE THE PROPERTY OF DELTA ELECTRONICS MFG CORP. AND SHALL NOT BE REPRODUCED, OR COPIED OR USED AS THE BASIS FOR THE MANUFACTURE OR SALE OF APPARATUS OR DEVICES WITHOUT THEIR EXPRESS WRITTEN CONSENT.

CODE IDENT.-00795

1007-013-A00E-3