

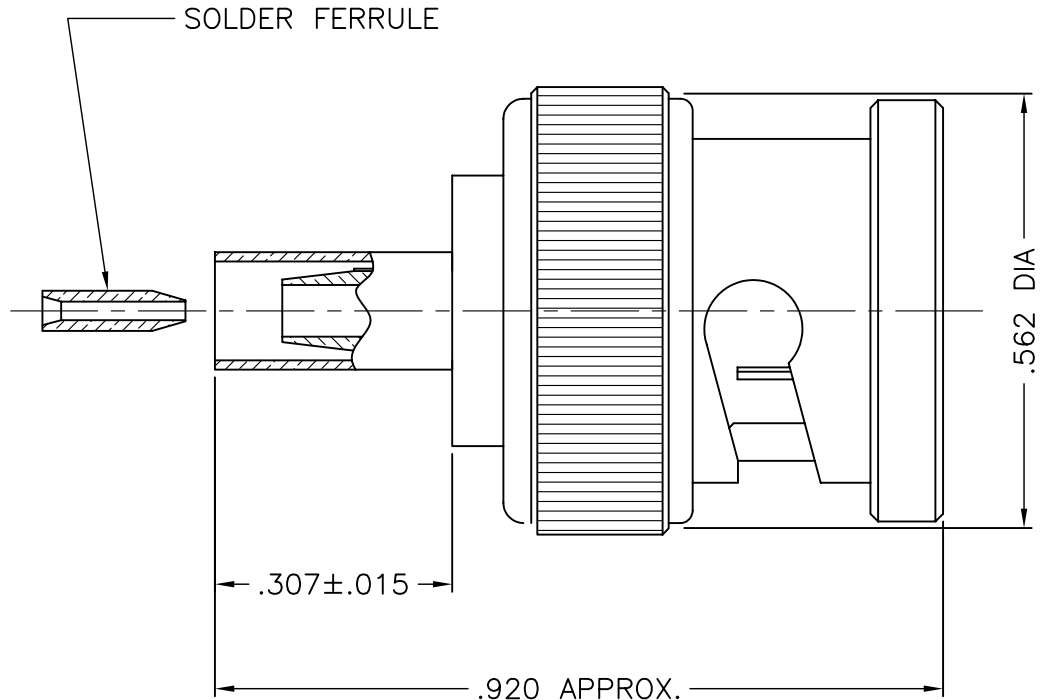

1003-037-N000



NOTES:

1. ASSEMBLED CONNECTOR INTERFACE IS DESIGNED IN ACCORDANCE WITH MIL-STD-348.
2. MATERIAL: BODY & BAYONET SLEEVE- BRASS PER ASTM B16
 CONTACT & SPRING WASHER - BERYLLIUM COPPER PER ASTM B196.
 INSULATORS - TEFLON PER ASTM D1710
 GASKET - SILICONE RUBBER PER ZZ-R-765
 CRIMP SLEEVE - D.H.P. COPPER CDA ALLOY 122
3. FINISHES: CONTACT (LOOSE) - GOLD PLATE PER MIL-G-45204
 CONTACT (INTERNAL) - SILVER PLATE PER QQ-S-365
 CRIMP SLEEVE - SULFAMATE NICKEL PLATE PER MIL-P-27418
 ALL OTHER PLATED PARTS - NICKEL PLATE PER QQ-N-290

DELTA ELECTRONICS MFG. CORP. Beverly, MA 01915

TITLE: 'BNC' CRIMP PLUG FOR RG-174,
 179B, 187A, 188A & 316 CABLES

UNLESS OTHERWISE SPECIFIED: TOLERANCES: 3 PLACES = ±.005, 2 PLACES = ±.02, ANGLES = ±1/2', SURFACE FINISH = 63	-	OUTLINE	11/30/05
	ALT.	REVISIONS	DATE

Drawn by BJM 11/30/05	Scale 4/1	Ckd. by MR	Engr Appd MR	FILE NAME: 1003037N000-000T
-----------------------------	--------------	---------------	-----------------	--------------------------------

THESE DRAWINGS AND SPECIFICATIONS ARE THE PROPERTY OF DELTA ELECTRONICS MFG CORP. AND SHALL NOT BE REPRODUCED, OR COPIED OR USED AS THE BASIS FOR THE MANUFACTURE OR SALE OF APPARATUS OR DEVICES WITHOUT THEIR EXPRESS WRITTEN CONSENT.

CODE IDENT.-00795 1003-037-N000