

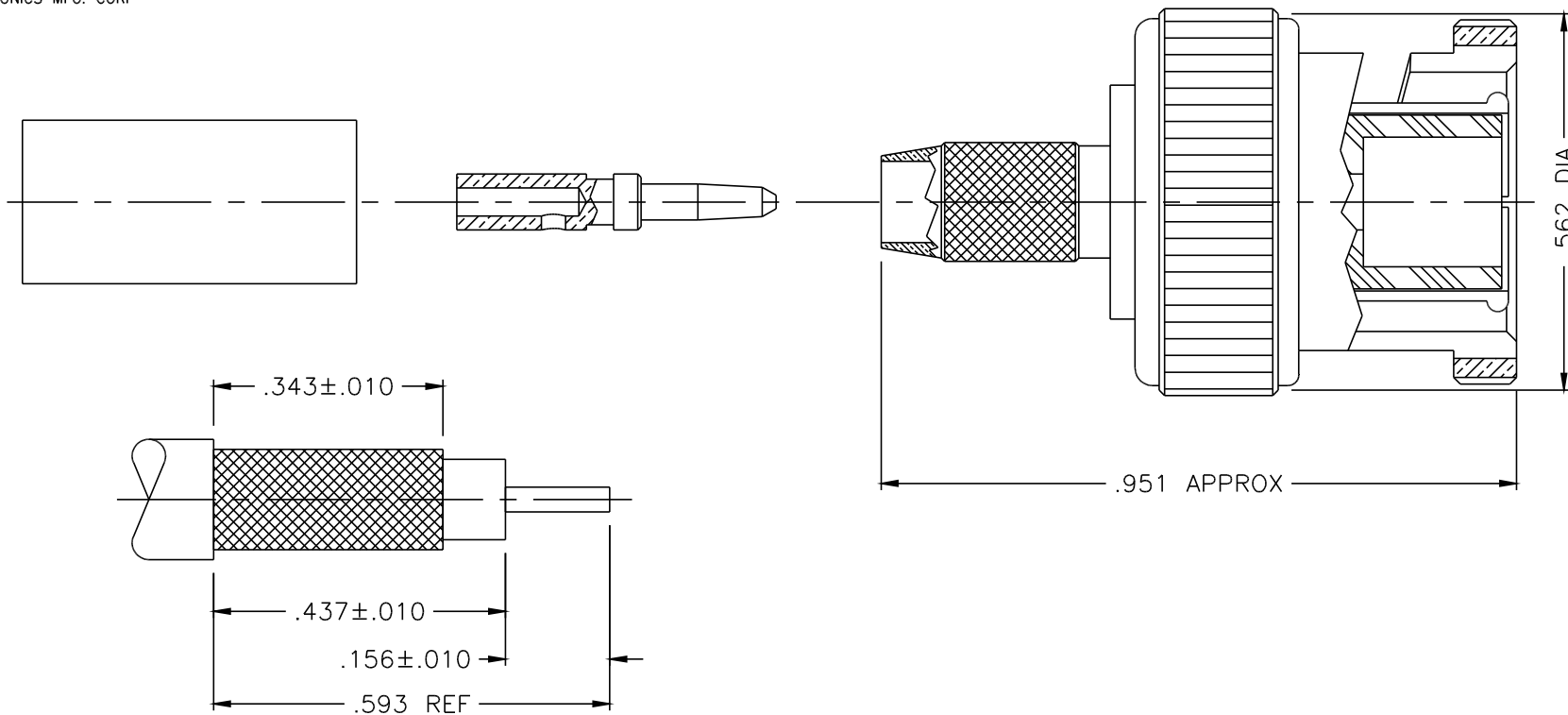

1003-013-N00E



CABLE TRIMMING DIMENSIONS

NOTES:

1. ASSEMBLED CONNECTOR INTERFACE IS DESIGNED IN ACCORDANCE WITH MIL-C-39102/16, CAT. 'D'
2. MATERIAL: CONTACT - BRASS PER ASTM B16.
INSULATOR - TEFLON PER ASTM D1710
GASKET - SILICONE RUBBER PER ZZ-R-765
CRIMP SLEEVE - D.H.P. COPPER CDA ALLOY 122
ALL OTHER METAL PARTS - BRASS PER ASTM B16
3. FINISHES: CONTACT - GOLD PLATE PER MIL-G-45204
CRIMP SLEEVE - SULFAMATE NICKEL PLATE PER MIL-P-27418
BODY, HEX NUT & LOCKWASHER - NICKEL PLATE PER QQ-N-290

UNLESS OTHERWISE SPECIFIED: TOLERANCES: 3 PLACES = ±.005, 2 PLACES = ±.02, ANGLES = ±1/2°

A	REDRAWN RWP	DATE
-	OUTLINE	5/17/94
ALT.	REVISIONS	DATE

DELTA ELECTRONICS MFG. CORP. Beverly, MA 01915				
TITLE: 'BNC' (M) CRIMP PLUG FOR RG-400/U & 142B/U CABLES				
Drawn by MCD 5/17/94	Scale 4/1	Ckd. by	Engr Appd	FILE NAME: 1003013N00E-000T
CODE IDENT.-00795		1003-013-N00E		

THESE DRAWINGS AND SPECIFICATIONS ARE THE PROPERTY OF DELTA ELECTRONICS MFG CORP. AND SHALL NOT BE REPRODUCED, OR COPIED OR USED AS THE BASIS FOR THE MANUFACTURE OR SALE OF APPARATUS OR DEVICES WITHOUT THEIR EXPRESS WRITTEN CONSENT.