

1010-020-N001-1

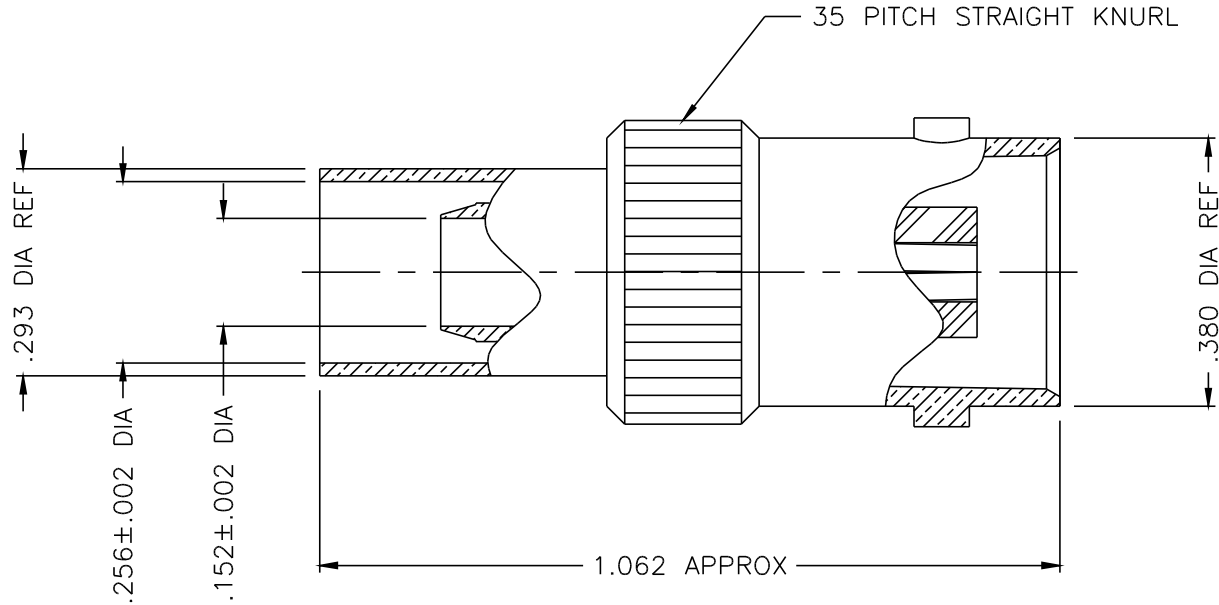

NOTES:

1. ASSEMBLED CONNECTOR INTERFACE IS DESIGNED IN ACCORDANCE WITH MIL-STD-348.
2. MATERIAL: CONTACT - BERYLLIUM COPPER PER ASTM B196.
INSULATOR - TEFLON PER ASTM D1710
CRIMP SLEEVE - D.H.P. COPPER CDA ALLOY 122
ALL OTHER METAL PARTS - BRASS PER ASTM B16
3. FINISHES: CONTACT & BUSHING - SILVER PLATE PER QQ-S-365
ALL OTHER METAL PARTS - NICKEL PLATE PER QQ-N-290
4. RECOMMENDED CRIMP TOOL M22520/5-19 CLOSURE A (.250 HEX DIA)

WANG 350-2201

DELTA ELECTRONICS MFG. CORP. Beverly, MA 01915

TITLE: 'BNC' SHORT CRIMP JACK FOR
RG-59/U CABLE

Drawn by MJA 9/2/97	Scale 4/1	Ckd. by	Engr Appd	FILE NAME: 1010020N001-001T
---------------------------	--------------	---------	-----------	--------------------------------

UNLESS OTHERWISE SPECIFIED: TOLERANCES: 3 PLACES = ±.005, 2 PLACES = ±.02, ANGLES = ±1/2°

A	REVISED	DATE
-	OUTLINE	5/8/89
ALT.	REVISIONS	DATE

THESE DRAWINGS AND SPECIFICATIONS ARE THE PROPERTY OF DELTA ELECTRONICS MFG CORP. AND SHALL NOT BE REPRODUCED, OR COPIED OR USED AS THE BASIS FOR THE MANUFACTURE OR SALE OF APPARATUS OR DEVICES WITHOUT THEIR EXPRESS WRITTEN CONSENT.

CODE IDENT.-00795

1010-020-N001-1